



General Information

With Solar Lighting Systems, street, park, beachside and garden lighting projects are realized by placing solar energy panels and batteries to store the energy produced during the day.

Application Areas



In Solar System lighting projects, the working voltage is usually designed as 12V or 24V. Because batteries and solar panels are generally preferred and produced at these voltages. Using MPPT (maximum power point monitoring) solar charge controller to operate the solar powered systems in accordance with the changing seasons and sunshine conditions, to prevent the batteries from being discharged when the solar panel does not produce energy, to charge the batteries optimally, to prevent the batteries from over-discharge and to use them longer. required. Although these devices are expensive compared to PWM chargers, they are much more efficient devices when cost/benefit is considered. Monocrystalline solar panels are preferred in our solar powered lighting systems. As for the battery, Deep Cycle Gel Battery or Lithium Phosphate batteries are recommended. In our recommendation systems, the most advanced devices and technologies preferred in the sector are preferred and Mono crystal solar panels varying from 165W to 330W and systems with 30W, 40W, 50W LED lighting power are recommended according to the desired illuminance value.

Solar Panel	165W	200W	330W
Battery	100 Ah / 1200 Wh	150 Ah / 1800 Wh	200 Ah / 2400 Wh
Operating Range	3 Days – 10 Hours/Day	3 Days – 10 Hours/Day	3 Days – 12 Hours/Day
Battery Type	Deep Cycle GEL Battery / LiFePO4		
Charger	MPPT Solar Charger		

Subsystems and Features



Solar Panel

- High efficiency Monocrystalline Solar Panel
- 24V
- 280W
- Compatible Connector MC4
- IP65 Koruma Sınıfı
- 10 Year System Warranty
- Max. Load: Wind- 2400Pa / Snow – 5400 Pa
- 1640mm x 992mm x 30mm

Valve Regulated Lead-Acid Batteries

- 12V
- 100 Ah
- 330mm x 173mm x 213mm



MPPT Solar Charge Controller



- Load: Lighting Control
- Max. Panel Input: 12V - 24V
- Max. Input Capacity: 20-40A (12V) – 60A (24V)
- Charge Management: MPPT
- System Voltage: 12-24V
- Operating Temperature: -25°C~60°C
- 13,6 x 7 cm

Street Lighting Luminaire

- Consumption Power: 50W
- Input Voltage: 12
- Body : Aluminum Injection
- Light Source: LED
- Optic : PC Lens
- IP Class : IP66
- Impact Resistance : IK 08
- Efficacy: 130 lm/W
- CRI : > 70
- Operating Temperature: -25°C~60°C



System Architecture



Monocrystalline
Solar Panel



LED Fixture



Valve Regulated Lead-Acid
Battery



MPPT Solar Charge
Controller



Armature Pole

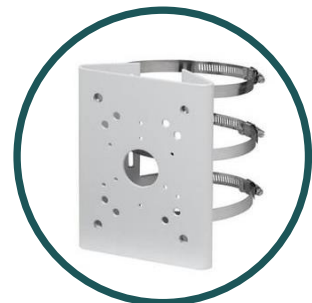

Mounting Bracket



URSA-M SOLAR LIGHTING SYSTEM

Standard Product Features

Body	: Aluminum Injection
Refractor	: High Permeability min. 4mm Tempered Glass
IP Class	: IP66
Usage	: Side or Top Entry Mount (Diameter $\Phi = 50 / 60$ mm)
Light Source	: LED
Optic	: PC Lens
Testing Standards	: TS EN 60598, TS EN 62031, TS IEC TR 62471, TS EN 60529, TS EN 62262, TS EN 62722-2-1

Optic and Electrical Features

Power	: 50W	Input Voltage	: 12V DC
Total Lumens	: 6500 lm	Surge Protection Opt.	: 2kV
Optic	: Asymmetric	Color Temperature	: 4000K - 6000K
Efficacy	: 125 lm/W	CRI	: >70

Other Features

Operating Temperature	: -25°C / +55°C	Lifspan	: 60.000 Hour
Impact Resistance	: IK 08 - IK 10 (Optional)	Cable Gland	: IP66, M16X1.5
Operating Time	: 6 - 14 Hour		

Technical Drawings and Images



3-6m

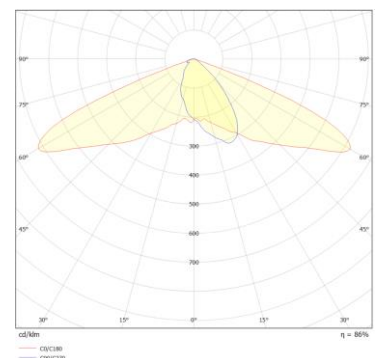
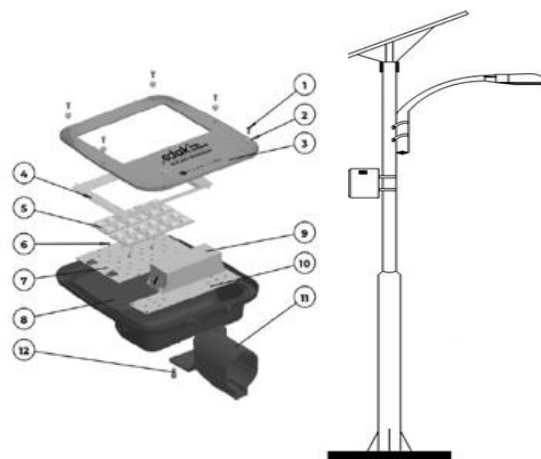
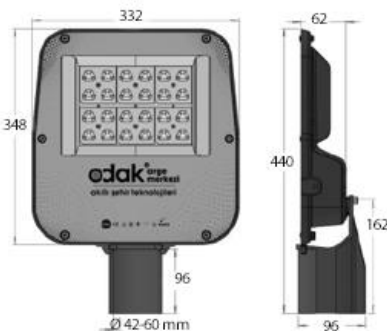

Optical Beam Angle: Asymmetric

Product Code	Power	Input Voltage	Luminous Flux	CCT	Light Angle	Dimensions
URS-030M-ASY12-850	30 W	24V DC	4200 lm	2700K - 6500K	ASM	281x385x96
URS-040M-ASY12-850	40 W	24V DC	5600 lm	2700K - 6500K	ASM	332x440x96
URS-050M-ASY12-850	50 W	24V DC	6500 lm	2700K - 6500K	ASM	332x440x96